



**TJ-70**

**MINI THERMOJET HANDPIECE**

**PACE P/N 7023-0002**

**OPERATION & MAINTENANCE**

**INSTRUCTIONS**

**MANUAL NUMBER 5050-0349**

**REV. A**

---

For any questions regarding the following instructions, contact your local authorized PACE dealer or contact PACE directly at:

Telephone (301) 490-9860, Fax (301) 604-9215

**PACE Incorporated**  
9893 Brewers Court  
Laurel MD 20723-1990



PACE Incorporated retains the right to make changes to specifications contained herein at any time, without notice.

Contact your local authorized PACE Distributor or PACE Incorporated to obtain the latest specifications.

The following are registered trademarks and/or servicemarks of PACE Incorporated, Laurel Maryland U.S.A. and may only be used to identify genuine PACE products or services:

AdapTip, Arm-Evac, Cir-Kit, ComForm I, ConducTweez, CRAFT, Dual Path, Flo-D-Sodr, FuseSet, HandiPik, HotSpot, LapFlo, MBT, Micro Portable, MicroChine, MiniChine, Pacenter, PACE, Ped-A-Vac, PETS, PIK-VAC, PRC, PRINT, Pro-Evac, ResisTweez, SensaTemp, SMR, SNAP-VAC, Sodr-X-Tractor, SR-3, SR-4, ST, StripTweez, SwaPlater, ThermoBand, ThermoJet, ThermoPart, ThermoPik, ThermoTweez, Thermo-Drive, Tip-Evac, VisiFilter.

The following are trademarks and/or servicemarks of PACE Incorporated, Laurel Maryland U.S.A. and may only be used to identify genuine PACE products or services:

EKO, Redi-Rak, Mini-Wave, Sodr-Pen.



PACE Incorporated has provided training on all of its products since 1958 as well as advanced technology training in all aspects of hand soldering, rework and repair.

Additional copies of this manual or other PACE literature may be obtained from:

PACE Incorporated	(301)490-9860
Sales Administration	(301)4983252Fax
9893 Brewers Court	
LaurelMD 20723-1990	

©1993 PACE Incorporated, Laurel MD. All rights reserved. Printed in the U.S.A.



This manual details the basic operational guidelines for using the TJ-70 Mini ThermoJet handpiece. A detailed Operation & Maintenance Manual For Accessories (P/N 5050-0350) is available from PACE.

## **CAPABILITIES**

The TJ-70 Mini ThermoJet Handpiece provides safe, continuous flow of precision focused hot air for component installation and SMT land preparation. It is primarily an installation tool and can be used for hot air installation of most surface mount components. Its slim-line, pencil grip design and finger actuated control switch facilitates ease of use and manipulation in tight places. The TJ-70 is a member of the PACE SensaTemp family of advanced handpieces.

### **CAUTION**

Always return heated handpieces to the appropriate Hot Cubby when not in actual use. Failure to do so may cause burns to the operator, equipment or work surfaces, and may be a potential ignition source if combustible materials are nearby. Always use this handpiece in a well ventilated area to avoid inhalation of fumes created by solder flux gases.

## **HANDPIECE SETUP**

Connect the handpiece power cable plug to one of the handpiece power receptacles on your PACE power source. PACE recommends that air handpieces utilize the power receptacles closest to the SNAP-VAC and Controllable PRESSURE Ports to minimize cord tangles. Connect an Air Hose to the TJ-70 using the method listed below. Determine the proper tip to install and install the tip in the method listed under "Tip Installation".

### **NOTE**

If using your TJ-70 Mini ThermoJet Handpiece for the first time or if you have just replaced the heater, we recommend that you follow the "TJ-70 Heater Burn-in" procedure (Red tag on handpiece) to increase the life expectancy of the heater and to minimize any smoke and fumes generated by the heater on its initial power-up.

## AIR HOSE CONNECTION

The Traditional Method of attaching the Air Hose from the power source is best suited for use with the TJ-70.

### NOTE

Ensure that no Air Hose is connected to the **SNAP-VAC** Port when using the TJ-70 handpiece. The TJ-70 Air Hose must be connected to the Controllable **PRESSURE** Port. Attachment to both ports simultaneously will cause a deterioration of performance.

### TRADITIONAL CONNECTION

1. Connect the 137cm (54 inch) length of Air Hose to the metal tube in the back of the handpiece.
2. Insert the ridged end of a male quick connect hose mount fitting (P/N 1259-0087) into the free end of the 137cm (54 inch) length of Air Hose.
3. Secure the Air Hose to the cable assembly with cable clips (P/N 1321-0085-01).
4. Attach the remaining end of the 137cm (54 inch) length of Air Hose (with attached male fitting) to the power source Controllable **PRESSURE** Port.
5. To avoid confusion among handpieces, PACE recommends the use of colored markers (P/N 6993-0136 Cable Marker Kit) to identify the Air Hose connected to the handpiece. Attach any two like colored markers, one to each end of the Mini ThermoJet Air Hose. Any Air Hose attached to another handpiece should contain markers of another color.

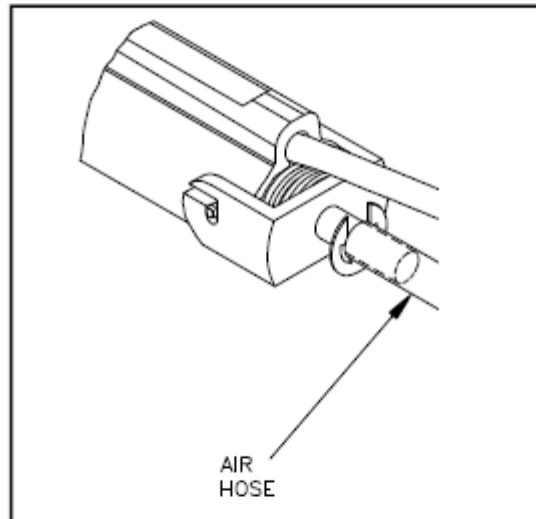

## **TIP INSTALLATION**

Tip selection is very important. Referring to the list of Available Tips (Table III), select the appropriate tip for your application.

The following instructions are for tip installation only. If a tip is currently installed in the handpiece, follow the "Tip Removal" procedure prior to the installation of a new tip.

1. Select the proper tip for your application. Refer to Table III.
2. Holding the handpiece in a horizontal position, the selected tip should be fully inserted until the tip seats itself against the heating element.

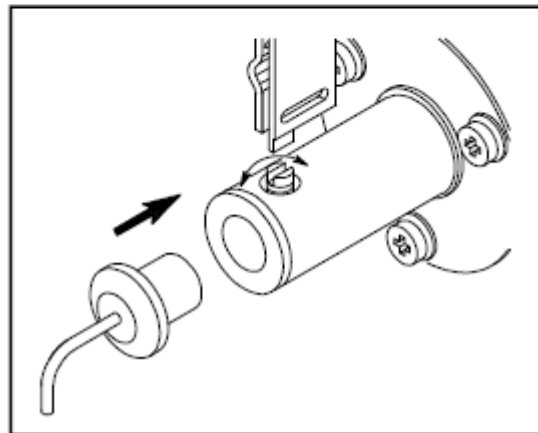

### **NOTE**

Holding the handpiece tip down may cause the tip to fall out before the set screw has been tightened.

3. Orient the tip with the finger switch on the handpiece as desired for optimum use.
4. Using the tip tool or small screwdriver, tighten heater set screw to secure. Do not over tighten.
5. Apply power to the handpiece and set the operating temperature to 482°C (900°F). After a short period (1-2 minutes) recheck the tip set screw to ensure that it remains snug. On very light boards, you may need to lower the temperature to protect the board from damage.





## **TIP PREPARATION**

TJ-70 tips are not tinnable and require little maintenance. Keep tips clean and free of any foreign particles. Insure that all tip air jets are kept clean to prevent air flow obstruction.

## **TIP REMOVAL**

### **NOTE**

To avoid tip damage, the Mini ThermoJet handpiece heater must be at a temperature of at least 177°C (350°F) before attempting to remove an installed tip. After removal, always place the hot tip in a tip holder or on a metal surface to prevent burns or scorches. Hold the handpiece with the heater body pointing up to prevent injury to personnel when cleaning a hot handpiece. Dispose of any loose debris properly. The debris is hot.

1. Loosen the heater assembly set screw.
2. Remove the tip using a tip tool or needle nose pliers.
3. Clean the heater bore to remove any foreign particles (i.e., flux) using the 3/16 inch diameter wire brush. Do not push the brush more than 0.64cm (1/4 inch) into the heater bore to avoid damage to the metal cylinder installed at the rear of the heater bore.
4. Replace the TJ-70 handpiece in the Hot Cubby.



## TEMPERATURE SETTING

Set the operating tip temperature of the channel powering the TJ-70 handpiece to 482°C (900°F). On very light boards, you may need to lower the temperature to protect the board from damage.

On MBT 250 and PRC 2000 systems, set the tip temperature offset to 3°C (6°F) (default setting).

## CONTROLLABLE PRESSURE PORT ADJUSTMENT

Air flow is actuated by depressing the finger switch on the handpiece or the optional foot pedal switch. The rate of air flow can be controlled by the Controllable **PRESSURE** Port on the front panel of the power source. Select and install a tip (see Tip Installation). Experiment using the procedure following to determine an appropriate level of air flow for your application.

1. Place a tissue paper (or like material) on the surface of your work bench.

NOTE
Insure that no flammable materials are positioned beneath the tissue. A Controllable <b>PRESSURE</b> Port setting of <b>MIN</b> to <b>3</b> is the best for general use. A setting of <b>MIN</b> to <b>1</b> are recommended when installing very small components such as chip capacitors.

2. With the Controllable **PRESSURE** Port set at minimum (**MIN**), press the finger switch on the handpiece and direct the hot air at the tissue from a distance of about 0.64cm (1/4 inch).
3. While continuing to depress the finger switch, slowly draw a series of burn lines on the tissue paper while increasing the Controllable **PRESSURE** Port setting slowly with the free hand.
4. Continue to experiment drawing the burn lines. Vary the the speed of handpiece movement, distance of the tip from the tissue and the Controllable **PRESSURE** Port setting until you become comfortable with handpiece use.

## **COMPONENT INSTALLATION**

Perform the following procedure to install the component.

### **NOTE**

To prevent damage to the component during placement, PACE recommends handling the component with a vacuum pick device such as the PACE Pik-Vac or HandiPik. Always place the hot tip in a tip holder or on a metal surface to prevent burns or scorches.

1. Carefully clean the replacement component leads (or terminations) and substrate land pattern area using an approved solvent. Insure that no leads or terminations become deformed during the process.
2. Apply solder paste to the lands.
3. Properly orient the replacement component with respect to the land pattern; centering the component leads (or terminations) with their corresponding lands.
4. Gently place the component onto the land pattern taking care to maintain proper lead to land alignment.
5. Apply a very small downward pressure to the component body; forcing the leads (or terminations) gently into the solder paste.

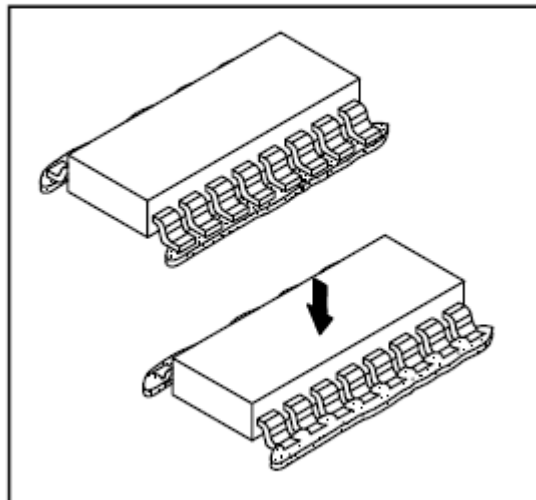





6. Bring the tip of the handpiece to a distance of 2.5cm (1 inch) from the component leads (or terminations). Press the finger switch to begin air flow. Direct the air flow to one side of the component and begin to heat the leads and lands in a side to side sweeping motion across the lead (or termination) or along the length of one row of leads. After evaporation of solder paste flux is observed, move the tip closer to the component with a continuous air flow until complete solder reflow occurs.
7. Continue to heat the lead/land contact area(s) until formation of shiny solder fillets is observed. Fillets on chip components and SOIC's will be slightly concave on each lead; fillets on extended lead devices should cover the sides, toe and heel of each lead.
8. Release the finger switch to stop air flow.
9. Repeat the above procedure for leads on all sides of the component.
10. Clean and inspect per your company specifications.

#### NOTE

If this process has not been successful, preheating of the PC Assembly and/or adjustment of the Controllable **PRESSURE** Port may be required.

## **SPECIAL APPLICATIONS**

If you require assistance in the use of this handpiece or require assistance with a special application, contact PACE Applications Engineering at:

Tel: (301)490-9860  
Fax: (301)604-9215



## **CORRECTIVE MAINTENANCE**

Your TJ-70 requires no special maintenance other than being kept clean. The heater bore and the heater assembly set screw which secures the tip must be kept free of oxidation and debris in order to maintain the proper tip to ground resistance. Periodically inspect the cable, connector and handpiece itself for evidence of physical damage. Do not use a handpiece with a damaged cable.

Refer to Table I (TJ-70 Heater Assembly Checkout Procedures) and the Connector Plug illustration below for information on troubleshooting most handpiece problems. Table II lists the common handpiece parts.

SYMPTOM	CHECKOUT PROCEDURE	CAUSE	SOLUTION
No heat	Check resistance - Pin 2 to Pin 5. If the resistance is greater than 7 ohms -	Open Heater	Replace Heater Assembly
	Check resistance - Pin 3 to Pin 6. If circuit reads open -	Open Sensor	Replace Heater Assembly
Handpiece overheating	Check resistance - Pin 3 to Pin 6. Resistance should be 110 ohms. If circuit reads less than 105 ohms -	Shorted Sensor	Replace Heater Assembly
No Ground on Tip	Check resistance - Pin 4 to a NEW Tip. Resistance should be less than 2 ohms. If not -	Oxidation buildup in Heater Bore	Clean Heater Bore using appropriate wire brush
		Defective Heater	Replace Heater Assembly

**TABLE I. TJ-70 HEATER ASSEMBLY CHECKOUT PROCEDURES**

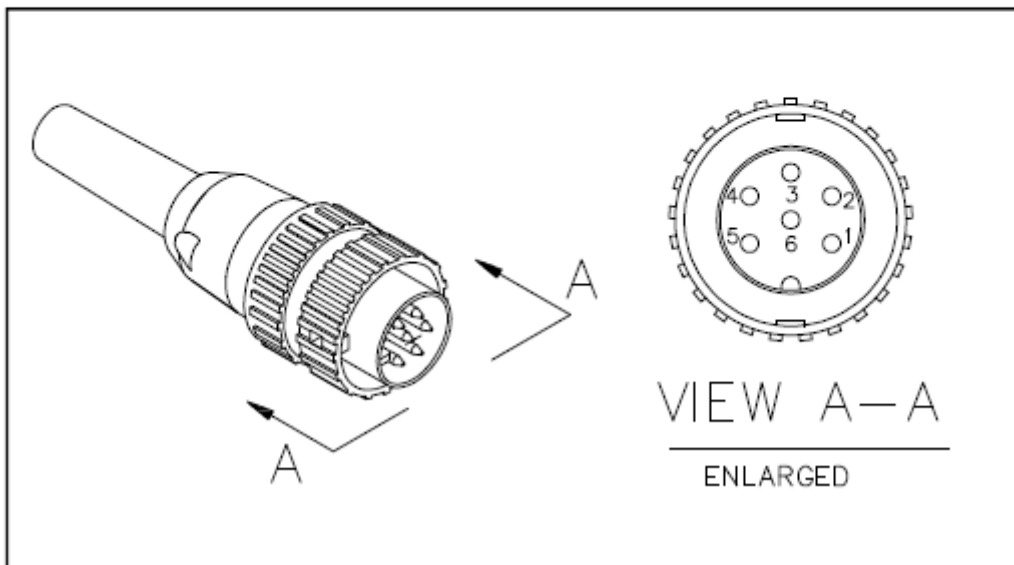

**CONNECTOR PLUG WIRING**

DESCRIPTION	PART NUMBER
HEATER ASSEMBLY	6010-0084-P1
CORD/SWITCH ASSEMBLY	6993-0134
HEATER SET SCREW	1348-0547
WIRE BRUSH, 3/16" DIAMETER	1127-0014
Handpiece tips listed following page	-----

**TABLE II. TJ-70 REPLACEMENT PARTS**



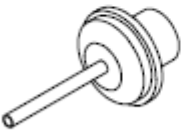

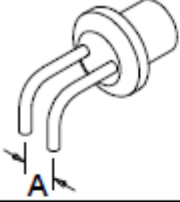
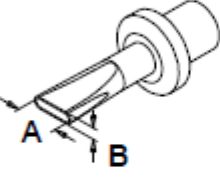
TIP	DESCRIPTION	TIP SIZE	PART NUMBER
	Small, Straight, Single Jet Tip	-----	1121-0366
	Small, Curved Single Jet Tip	-----	1121-0338
	SOT/Chip Component Tip (dual-jet)	A = 0.14" (3.56mm)	1121-0329
	SOIC Tip (dual-jet)	A = 0.17" (4.32mm)	1121-0330
	SOICL Tip (dual-jet)	A = 0.37" (9.40mm)	1121-0331
	Flat End Tip	A = 0.28" (7.11mm) B = 0.074" (1.88mm)	1121-0365
		A = 0.24" (6.10mm) B = 0.074" (1.88mm)	1121-0371

TABLE III. TJ-70 AVAILABLE TIPS